

Ghibli Firewood

Where
technology
meets tradition.

Ghibli Firewood utilizes wood combustion for roasting. Roasting occurs by means of convective hot air that flows across the roasting drum, transferring heat and the aroma of the wood to the beans. With this method of roasting, the end result is influenced by the type of wood being used, from natural coals to aromatic chopped fruit-wood or other aromatic types such as oak.

The Ghibli Firewood is one of the most advanced roasters in the industry. The roasting process can be conducted manually by digital temperature control or automatically by the accompanying software. Heat is directed to the drum housing for heating through a pneumatic selector box that features a waste gate connected to the chimney, which can block heat quickly.

The Ghibli Firewood operation is extremely clean and simple, with a highly efficient firing group that consumes a small amount of wood per batch. For example, one batch will only use roughly two pieces of wood, depending on its size.

Using the Ghibli Firewood to roast is much more than just another marketing highlight - it is joyful and, in a way, easier and more intuitive than roasting with gas, as only an organic heating source is being used. This also adds a whole world of flavours to your precious coffee. Wood aroma is the only legitimate addition to the aromatic spectrum of your coffee. Nevertheless, roasting with a neutral flavour is easy - simply use natural coals.

Roasting times with the Firewood are relatively short as a batch of 15kg can be roasted in 11 to 16 minutes. Roasting with the Firewood requires a pressurized air source for the selection box actuator.



Technical Specifications

Batch Capacity:

3-15 kg

Roasting Cycle:

12 minutes ± Up to 4 batches per hour

Electrical Specifications:

50/60 Hz. 2500 W 380 V 3 phases

Heating Method:

Traditional wood/charcoal heating

Chaff Evacuation:

Cyclone type chaff collector with booster blower - for clean in-house roasting

Drum Operation:

Direct drive individual heavy-duty gear motor 1/2 hp digital variable drum speed control included

Cooling Agitation:

Direct drive individual heavy-duty gear motor 1/3 hp.

Cooling Blower:

High capacity cooling blower, cooling time is about 1-2 minutes

Drum Venting:

Individual blower 1/3hp digital variable speed control included

Bearings:

Four main bearings, two (F&R) precision dry bearing with zero tolerance for centering the drum and two high temperatures, self-aligned bearings, micrometric drum alignment mechanism

Body:

Full precision metal work, top quality material and hardware, galvanized steel, carbon steel and stainless steel

Safety:

Safety drum discharger

Dimensions (cm):

114 (w) X 148(d) X 180 (h) cm (45"(w) X 58"(d) X 71"(h)) (With cyclone)

Weight:

400 kg (882 lb)

Also Available:

Automatic software

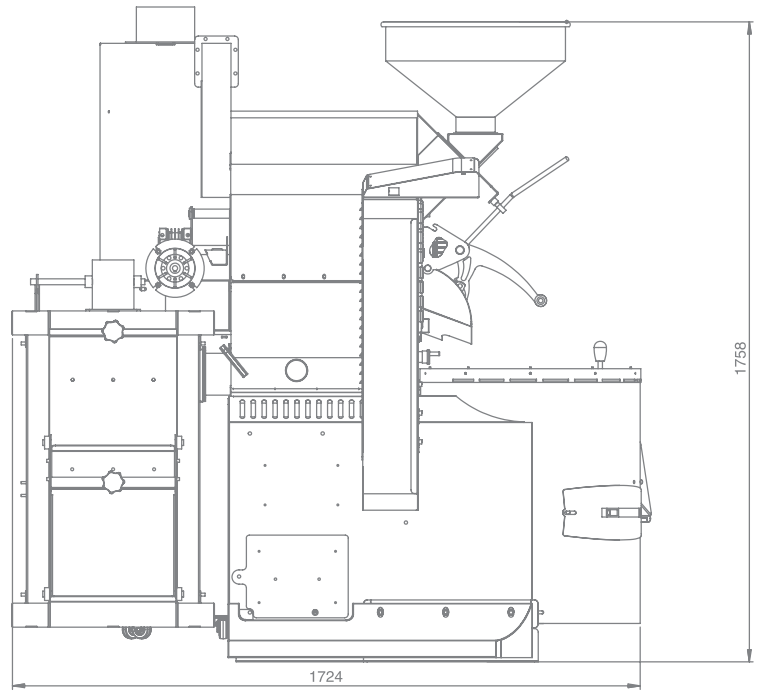
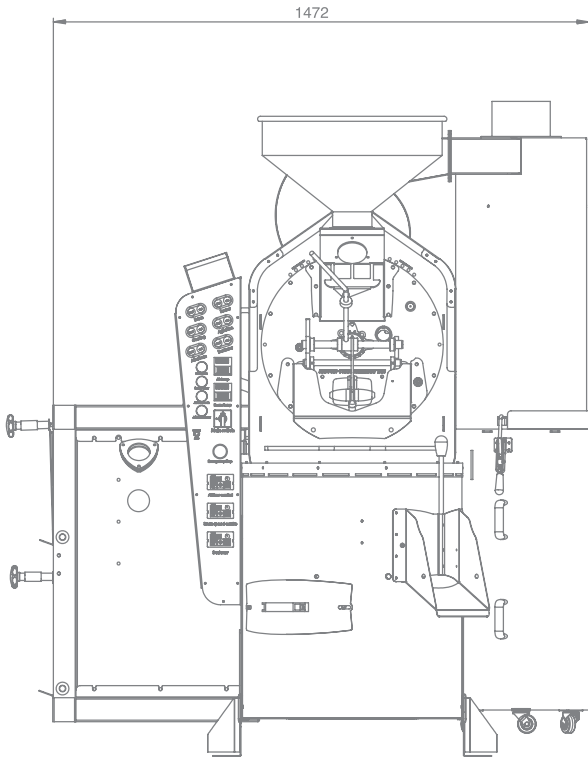

Heating Technology



Conduction



Convection



Indirect Flame



Wood Heating

Control Features



Drum Speed Control



Blower Speed Control



RDL

Optional



Smoke Free



Infrared Drum



Green Product

Roasting Method



Drum Roasting

General Features



Ceramic Chamber



Multi Point Temp.



In Drum Extinguish



Low Energy Consumption